

Operation Manual

MPC-A
MPC-K
MPC-L

mobile compactor

WERNER  WEBER

WERNER & WEBER Warenhandelsgesellschaft m.b.H., A1050 Wien, Margaretengürtel18/2, Austria
Tel: +43/1/544/92/40, Fax: +43/1/544/92/20, e-mail: infoline@werner-weber.com, www.werner-weber.com



INTRODUCTION

The present operation manual for waste compactors of the types MPC-A, MPC-K and MPC-L includes a detailed product description, instructions for appropriate handling and operational safety, and important information on accident- and product failure prevention.

Operators are invited to study this manual carefully prior to initial operation of the machine and to consult it on a regular basis for the sake of compliance with the instructions provided herein. Fail-safe operation and long product life will be your reward.

No product liability is accepted for damages resulting from inadequate use or handling of our waste compactors. No claims whatsoever - including claims regarding product design - can be derived from the contents of this operation manual.

In case of further questions or queries, you are kindly referred to our customer service department.

WERNER  WEBER			
Warenhandelsges.m.b.H., A-1050 Wien, Margareten­gürtel 18/2 Tel.: +43/1/544 92 40 www.werner-weber.com			
Type:	<input type="text"/>	max. Druck:	<input type="text"/> bar
Baujahr:	<input type="text"/>	Leistung:	<input type="text"/> kW
Leergewicht:	<input type="text"/> kg	Spannung:	<input type="text"/> V
Ges.Gewicht:	<input type="text"/> kg		
Serien Nr.:	<input type="text"/>		

WERNER WEBER

WERNER & WEBER Warenhandels­ge­sell­schaf­t m.b.H., A1050 Wien, Margareten­gürtel18/2, Austria
Tel: +43/1/544/92/40, Fax: +43/1/544/92/20, e-mail: infoline@werner-weber.com, www.werner-weber.com

TABLE OF CONTENTS

	Page
1. Safety instructions	3
Danger- and information signs	5
2. Description	6
2.1. Use	6
2.2. Description of main components	6
2.2.1. Type MP-A	6
2.2.2. Types MPC-K and MPC-L	7
2.2.3. Ancillary equipment	7
2.2.4. Operation panel	8
2.2.5. Hydraulic power pack	8
2.2.6. Service opening / ram face	9
2.2.7. Locking of the discharge door, type MPC-A	9
2.2.8. Tip bar, type MPC-A	9
2.2.9. Lifting bar, types MPC-K, MPC-L	10
2.2.10. Locking of the discharge door, types MPC-K, MPC-L	10
2.2.11. Discharge door catch	10
3. Operation / handling	11
3.1. Installation instructions	11
3.2. Initial operation	12
3.3. Trouble shooting	13
4. Care and servicing	14
4.1. Periodical maintenance	15
5. Annex:	
Technical Data	16
Dimensions	17
Lubricating scheme	18
Hydraulic diagram	19
Circuit diagram standard design	20
Circuit diagram 3/4 full indication	21
EC declaration of conformity	22

1. SAFETY INSTRUCTIONS

Important notes on technical and operational safety are especially highlighted:

DANGER



relates to operation procedures requiring strict compliance with instructions in order avoid hazard to persons and includes remarks on special worksite hazards.

CAUTION



relates to operation procedures requiring compliance in order to rule out product damage.

1. Prior to initial operation, familiarize yourself with the operation- and maintenance manual. Make sure to also have read and understood any additional remarks that may apply to special product features/optionals. A copy of the operation manual must be kept attached to the machine.
2. Operation, maintenance, and repair of the machine is reserved to authorised personnel. Legal minimum age requirements must be met.
3. Do not employ unskilled or poorly trained staff and clarify competencies in regard to product operation, maintenance, and repair beforehand.
4. Authorize the responsible operating staff to reject third party instructions that are an apparent safety hazard.
5. Workshop trainees or apprentices must not operate (or otherwise tamper with) the machine in the absence of an experienced operator.
6. Perform regular checks to ensure staff's compliance with the safety instructions provided in the manual.
7. Do not operate the machine without proper clothing.
 - 7.a. Avoid rings, wrist watches, ties, scarfs, open jackets, loosely fitting clothes, etc. Do not risk injury by pulling in or catching on.
 - 7.b. Note that certain procedures require special clothing such as safety shoes, hard hat, gloves, etc.....
8. Check out the location of the nearest fire extinguisher and familiarize yourself/-ves with its operation. Solicit information on local fire alarm and -fighting possibilities. Avoid the handling of fire or open light near the charging opening.

9. **Note before initial operation** (instructions on page 12):
 - 9.a. Never start operation without prior inspection of the machine; check if danger signs are missing or illegible.
 - 9.b. Note all danger and safety signs.
 - 9.c. Steady all loose machine parts.
 - 9.d. All covers and openings must be closed prior to the start of operation.
 - 9.e. Make sure to close all service openings immediately after servicing/maintenance.
 - 9.f. Prior to any operation, alarm all persons standing or working near the machine and check that nobody is working on top of it or inside it.
10. For special uses, the machine must be fitted with certain safety components. Start operation of the machine only with these parts fitted and in good operational condition and with all maintenance lids closed.

11. **Note before care and servicing** (instructions on page 14):

- 11.1. Unless instructed otherwise, proceed as follows in the event of maintenance- and repair works:
 - 11.1.a Stop motor.
 - 11.1.b Switch off main switch and padlock machine against unauthorised operation. Remove key from padlock and keep it during maintenance. Disconnect supply mains from plug.
- 11.2. Prior to opening (any repair work), the respective hydraulic parts, including pressure pipes, must be depressurized.
- 11.3. Make sure that all supports and protection pads against vibration, friction, and heat build-up are properly adjusted.
- 11.4. Check all electrical equipment for defects such as loose connections or worn cables. The repair of electrical equipment must be reserved to skilled personnel.
- 11.5. Regularly check all ducts, hoses and screwed connections for leakages and other damages. Remove leakages immediately and replace damaged parts. Oil leaking through untight spots is a risk of fire.
- 11.6. Do not service the hydraulic unit other than in cold condition.

DANGER



Oil leaking through untight spots is a risk of fire. Make sure to wear gloves when looking for leakages.

Note that the hydraulic oil may be very hot even before reaching operating temperature. Avoid any contact with hot oil or hot lubricated parts.

- 11.7. Never jump off the machine but use the steps, ladders, and gangboards instead.
12. Never start operation of a defective machine. Have defects repaired on the spot.

13. **Note before machine cleaning:**

- 13.a. Handle all process materials with care. Do not use any inflammable liquids for machine cleaning.
- 13.b. Close, seal or remove all apertures through which no water/cleaning liquid must penetrate during cleaning with water or water vapour (high pressure cleaner).

14. **Note before machine operating:**

- 14.1. Use appropriate hoists (as per DIN 30722 German Industrial Standard). All loads must be carefully attached to the hoists.

<p>CAUTION</p> 	<p>Do not exceed the maximum permissible total weight of 12 t (MPC-A) or 15 t (MPC-K, MPC-L) !</p>
---	--

<p>DANGER</p> 	<p><i>During the operation of hoists, it is strictly forbidden to stand or work beneath them.</i></p> <p><i>Always wear gloves when working with metal ropes.</i></p>
--	---

- 14.2. Inexperienced personnel must never be authorized to perform loading or give directions to crane or truck drivers. When giving directions, remain within each other's sight or hearing.
- 14.3. The machine must always be supported in such a way that weight transfers do not cause unsteadiness. Avoid that steel rests on steel.
- 14.4. For maintenance/repair works above body height, adequate ladders and/or platforms are necessary. Never use machine parts for climbing. All handles, steps, rails, platforms, ladders, and the like must be kept clean and free from dirt, grease/oil, snow, and ice.
- 15. Do not effect any modifications on the machine, such as rebuilding or adding-on, without the supplier's prior approval. This also applies to the mounting and adjustment of safety installations and -valves and to the welding of supporting structures.
- 16. Danger- and information signs:

at the chargebox

at the discharge door

<p>CLEAN CHARGEBOX EVERY WEEK</p> <p>DISCONNECT FROM POWER SUPPLY BEFORE OPENING THE FLAP</p>
--

<p>CHARGEBOX DANGER OF LIFE DO NOT ENTER!</p> <p>CUT OFF POWER PRIOR TO ANY MAINTENANCE WORK!</p>

<p>DANGER</p> <p>KEEP CLEAR OF THE DOOR WHEN FLAP OPENS!</p>

2. DESCRIPTION

2.1 USE

With a capacity of 8-25m³, waste compactors of the types MPC-A, MPC-K and MPC-L are suitable for all major skip and roll-on/off container handling units. These waste compactors compact your waste down to a fifth of its original volume and are suitable for any kind of household and industrial waste such as wooden cases, packaging material, paper, cardboard, etc. They are not suitable for sand, gravel, rubble, hot ashes, inflammable, acidic or alkaline substances, or heavy metal parts (such as profiles, beams). Waste compactors of the types MPC-A, MPC-K and MPC-L are designed for a temperature range of -20 to +60 degrees Celsius.

2.2 DESCRIPTION OF MAIN COMPONENTS

2.2.1. WASTE COMPACTOR of the type MPC-A (Skip loader unit)

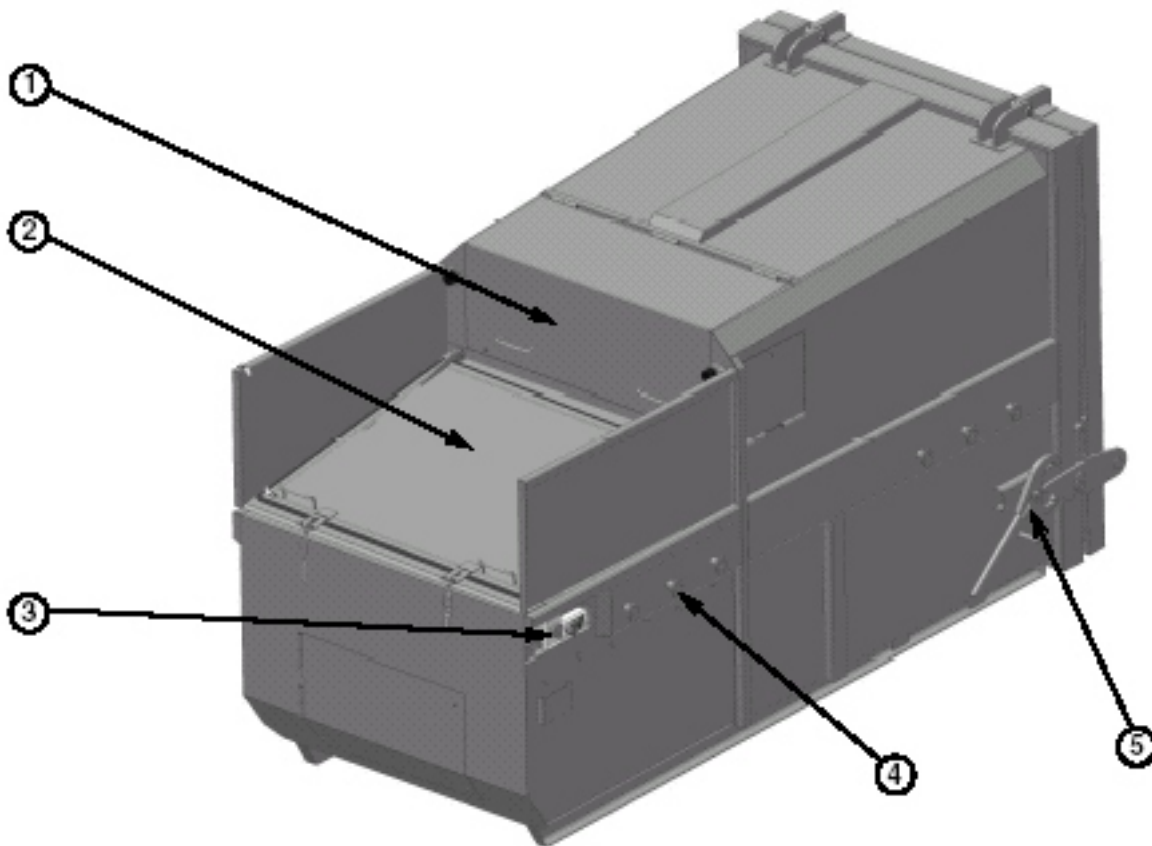

Overall view with optional side walls and hopper lid

1 hydraulic cabinet
2 hopper lid
3 operation panel

4 lifting pins
5 discharge door lock

2.2.2. WASTE COMPACTOR of the types MPC-K and MPC-L (Roll on/off unit)

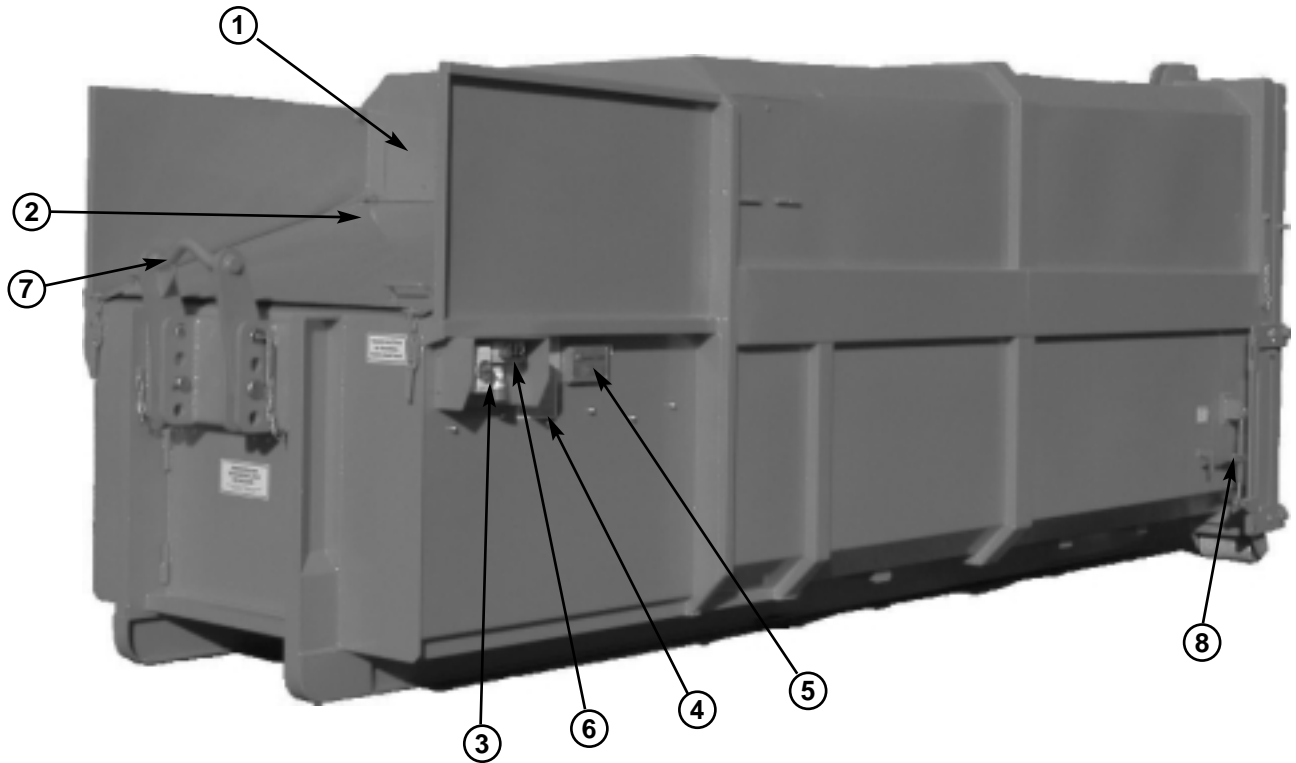

Overall view with optional side walls and hopper lid

1..... hydraulic cabinet
2.....hopper lid (optional)
3.....high-voltage connection

4.....information sign
5.....type plate
6.....operation panel
7.....lifting bar
8.....discharge door lock

2.2.3. OPTIONALS

Waste compactors may be equipped with the following optionals:

- Hoppers
- Hoppers with lid
- Hydraulic container dumping system
- Container liquid sealed
- Bilateral braces for container handling systems
- Supplementary rolls (front)
- 95% or 100% container full warning
- Limit stop switch for ram face (open or closed position)

2.2.4 OPERATION PANEL

Control of the machine is via the operation panel, mounted next to the charging opening:

- 1.....The main switch serves for switching the power supply on and off.
- 2..... By pushing the start button, the compaction process is started.
- 3..... The machine may be switched off by pushing either of the two EMERGENCY-OFF buttons on its lateral faces. For restarting, both EMERGENCY-OFF buttons must be unlocked.
- 4..... The release switch serves for gradual opening of the ram face in case of emergency.
- 5..... The power cable is connected to the socket by means of a CEE-standard plug.

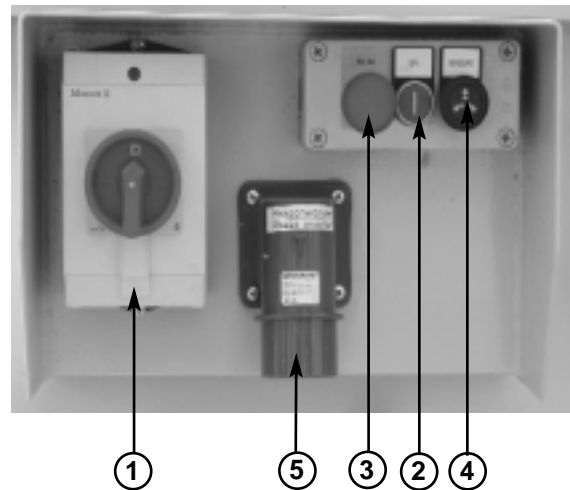

2.2.5. HYDRAULIC POWER PACK

The hydraulic power pack is located above the charging opening and comes in closed design with maintenance lid. The power pack serves for the control and supply of the two hydraulic cylinders behind the ram face.

The hydraulic unit consists of the following components:

- 1 motor with hydraulic pump
- 2 control valve
- 3 oil tank
- 4 oil filler
- 5 oil filter
- 6 oil level gauge
- 7 control cabinet

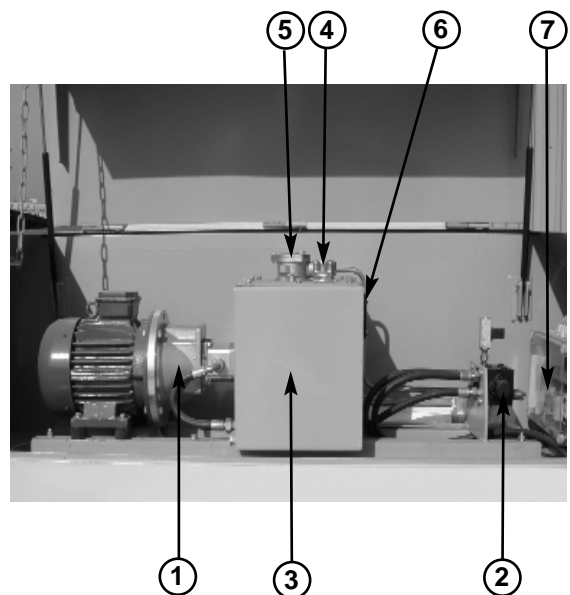

2.2.6. SERVICE OPENING / RAM FACE

The service opening is situated below the charging opening and is closed by means of a maintenance lid with limit switch protection. The compaction box accommodates the ram face, which is operated by means of two hydraulic cylinders.

DANGER



*Never enter the charge box without pushing the **EMERGENCY-OFF** button, switching off the main switch and padlocking against unauthorised operation. Remove key from padlock and keep it during maintenance. Disconnect supply mains from plug!*



2.2.7. Locking of the DISCHARGE DOOR, type MPC-A

The discharge door is fitted with a special locking mechanism. Secure locking mechanism always with the safety lever.

DANGER



Note that the discharge door must be closed and locked before starting the compaction process.

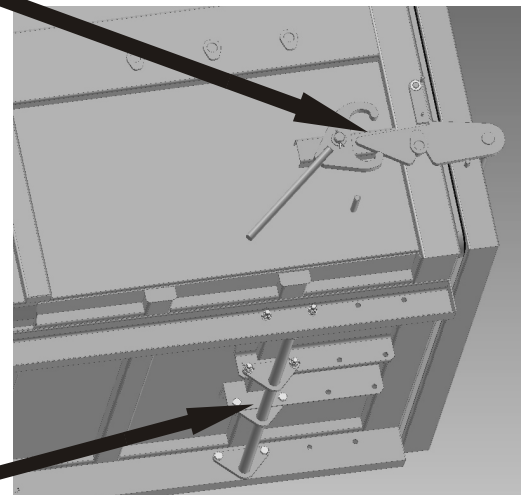

2.2.8. TIP BAR, type MPC-A

All waste compactors fitted with skip vehicle attachments come with an adjustable rail (adjustment depending on vehicle type) for catching on of the tipping hook.

CAUTION



Do not exceed the maximum permissible total weight of 12 t (MPC-A)!

2.2.9. LIFTING BAR, types MPC-K/MPC-L

The lifting bar for the roll on/off unit are hinged and adjustable for both standard hook heights.

CAUTION



Do not exceed the maximum permissible total weight of 15 t (MPC-K/MPC-L)!

Any handling of the compactor requires bolting of the hook (with supplied bolts)!



2.2.10. Locking of the DISCHARGE DOOR, types MPC-K/MPC-L

The discharge door is provided with a ratchet locking mechanism. Turn the lever for opening or closing locking mechanism.

DANGER



Note that the discharge door must be closed and locked before starting the compaction process.

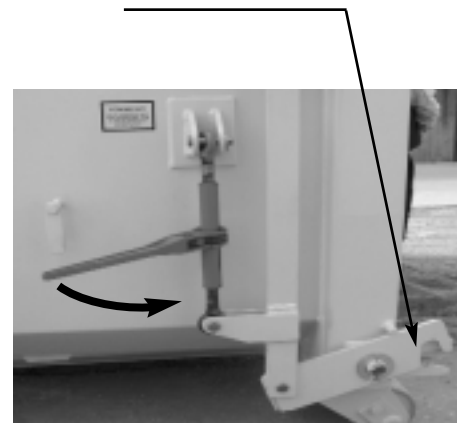

2.2.11. DISCHARGE DOOR CATCH

The discharge door has a mechanism designed for fastening the open door during the discharge operation.

DANGER



Make sure that the open discharge door is fastened before starting the discharge operation.



3. OPERATION / HANDLING

3.1. INSTALLATION INSTRUCTIONS

DANGER

Read and follow these and the safety instructions of chapter 1 !



1. Note the following safe-floor loads:
 - a. for skip units not less than 13.000 N/m² ,
 - b. for roll on/off units not less than 17.000 N/m² .
2. Provide sufficient space at the installation site for transportation with the skip unit or roll on/off unit.
3. If charging of the waste compactor is done from a loading dock or platform(s), make sure that the hopper is at least 1 m above ramp height (i.e. operator's location)!
4. Note that the floor for installation of the compactor should be even.
5. If required, provide additional lighting at the installation site (in accordance with AAV).
6. Protect installation site against accessing by unauthorized personnel.
7. Note that the power supply at the installation site must be protected by means of a safety switch (with a sensitivity of 30mA) and a 16A fuse.
8. The supply cable must have a cross-section of 5 x 2.5 mm² and should be fitted with a 16A CEE-standard socket.
9. Movable supply cables require a solid (rubber) hose pipe of the type HO/RN-F according to VDE 0100.

3.2. INITIAL OPERATION

The machine is ready for operation after a test run. The following safety checks are necessary prior to initial operation of the compactor:

DANGER



The operating personnel must be familiar with machine handling and observe the safety instructions !

All service openings must be closed !

Make sure there is no person inside the charge box before starting operation !

The discharge door must be locked !

The maintenance door of the hydraulic unit must be closed during operation !

- 1 Connect the compactor to electrical supply.
- 2 Switch on main switch.
- 3 Unlock the EMERGENCY-OFF button (on both sides).
- 4 Push start button.

The ram face must move backward within 5 seconds. Immediately switch off the motor if it fails to do so, since the pump will not be lubricated once the motor takes the wrong direction. Reverse poles of the plug in the machine socket by switching the pole changer.

5 After starting the motor, the ram face will alternately move forward and backward. For this purpose, two hydraulic cylinders alternately move up and down. The movement of the hydraulic cylinders is reversed by means of a hydraulic control unit. For protection of the hydraulic unit, the power unit is equipped with a time lag relay, which automatically stops the hydraulic operation after a set period of time, at any point between 0 and 12 minutes.

6 Charging of the waste may continue up to the point where the ram face fails to clear the charging opening.

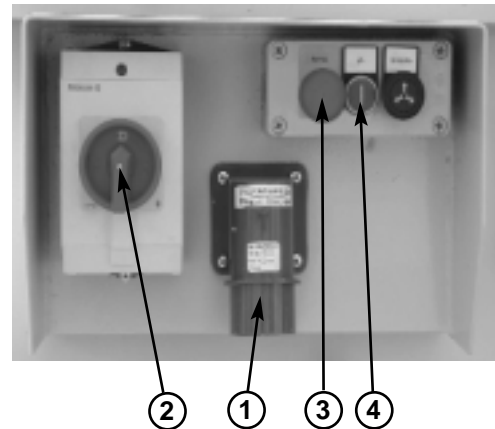

CAUTION



*Never leave the operation panel unattended during the compaction process; the machine must be switched off immediately in case of emergency !
The panel may be left unattended only after operation is discontinued !*

3.3. TROUBLE SHOOTING

PROBLEM	SOURCE	SOLUTION
machine cannot be switched on	power supply motor defective	<ul style="list-style-type: none"> - check mains supply - switch on main switch - release both EMERGENCY-OFF switches - close maintenance lid of charge box - check fuse and motor protection in power unit - check safety switch and fuse of mains supply - replace motor
motor runs, ram face does not operate	<p>polarity</p> <p>too little hydraulic oil</p> <p>main valve defective</p> <p>hydraulic pipes and hydraulic unit leak</p> <p>pump defective</p>	<ul style="list-style-type: none"> - change 2 of the 3 phases of plug connection - check oil level and refill if required - main valve defective - hydraulic unit leak - replace pump
ram face toes out during operation	ram face guide loose	- call service
telescope plates do not stay within guides		- call service

CAUTION



Call a service technician for all problems operating personnel cannot handle and for problems not listed above !

4. CARE and SERVICING

Waste compactors require very little servicing. However, compliance with the following instructions is recommended to ensure failsafe operation and long machine life.

Conclusion of a service agreement is optional, yet recommended. Under such agreement, our service staff will service your plant twice a year. Our specialists will identify potential problems hands-on, thus avoiding major failures.

Service range:

1. inspection of hydraulic unit
2. adjustment (if required)
3. inspection of power unit
4. lubrication
5. filter cleaning
6. oil change (once a year)
7. overall inspection

DANGER



During all maintenance work, compliance with the following safety instructions (also see chapter 1) is required:

1. Switch off main switch and padlock machine against unauthorized operation. Remove key from padlock and keep it during maintenance.
2. Push the EMERGENCY OFF button and disconnect supply mains from plug!
3. Do not remove or deactivate protections!
4. Do not change setting of the hydraulic control unit (sealed). In case of replacement, original spare parts suitable for an operating pressure of 250 bar must be used!

4.1. PERIODICAL MAINTENANCE

Weekly:

- Clean box behind ram face. Maintenance intervals will depend on the kind of waste processed and frequency of compaction.
- Check all parts of the hydraulic unit for tightness.

1 Clean back flow oil filter. Remove cover of hydraulic cabinet and open screws for taking out filter and subsequent cleaning.

2, 3 Check oil level and refill hydraulic oil (HLP 22) via the filler.

- Check all electric parts for possible damage.

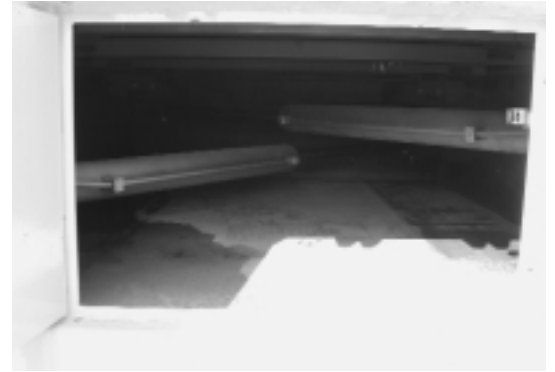

DANGER Do not service the hydraulic unit other than in cold condition !



Close charging opening (safe to step on) before servicing.

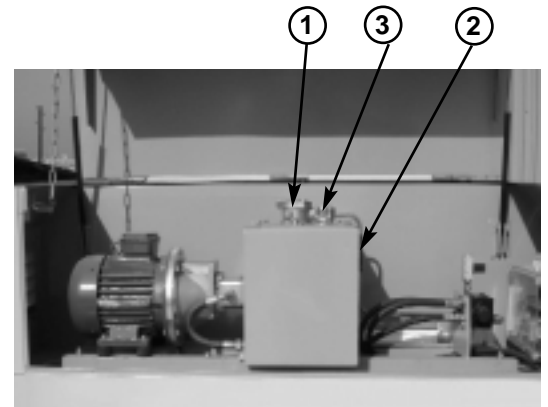

Quarterly:

- Check hydraulic unit for tightness. Lubricate guides with Signum LM grease.
- Lubricate nipples of the rollers, hydraulic cylinder and door hinges with Signum LM (see lubricating scheme).

Once a year:

- Change hydraulic oil (HLP 22).

ANNEX: TECHNICAL DATA

Handling system		Dim	Skip unit		Roll on / off unit							
Type			MPC10A	MPC12A	MPC16-K	MPC18-K	MPC20-K	MPC25-K	MPC16-L	MPC18-L	MPC20-L	MPC23-L
Effective capacity		(m ³)	10	12	16	18	20	25	16	18	20	23
Ram force (cylinder)		(kN)	230	230	330	330	330	330	330	330	330	330
Total length (A)	A	(mm)	4520	5170	5370	5770	6220	7220	6260	6660	7110	7860
Total width	B	(mm)	1990	1990	2420	2420	2420	2420	2420	2420	2420	2420
Height	C	(mm)	2360	2360	2650	2650	2650	2650	2650	2650	2650	2650
Opening length	D	(mm)	1440	1440	1440	1440	1440	1440	2330	2330	2330	2330
Opening height	E	(mm)	1300	1300	1340	1340	1340	1340	1340	1340	1340	1340
Opening width	F	(mm)	1630	1630	1948	1948	1948	1948	1948	1948	1948	1948
Roller distance	G	(mm)			2160	2160	2160	2160	2160	2160	2160	2160
Ram stroke	H	(mm)	1230	1230	1230	1230	1230	1230	1980	1980	1980	1980
Stand width	J	(mm)	1280	1280								
Roller width	K	(mm)			300	300	300	300	300	300	300	300
Empty weight		(kg)	3340	3560	4070	4190	4320	4650	4580	4700	4830	5080
Gross weight		(kg)	12000	12000	15000	15000	15000	15000	15000	15000	15000	15000
Min. cycle time forw/backw.		(sec)	22	22	30	30	30	30	50	50	50	50
Motor		(kW)	5,5	5,5	5,5	5,5	5,5	5,5	5,5	5,5	5,5	5,5
Power supply	380 V, 50 Hz - standard plug CEE-form 16 A, 5-pole											

Change of technical data reserved.

ANNEX: DIMENSIONS

Types
MPC-K and MPC-L

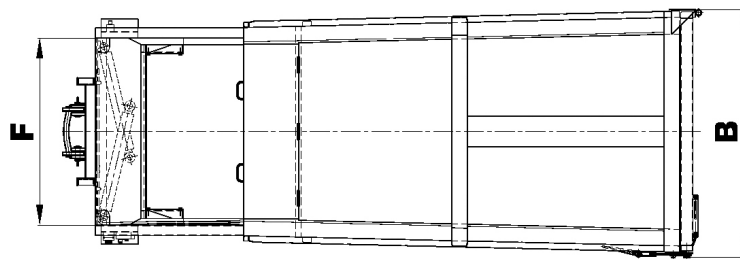
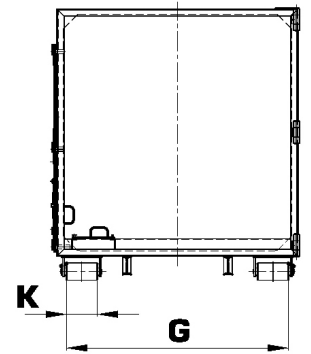
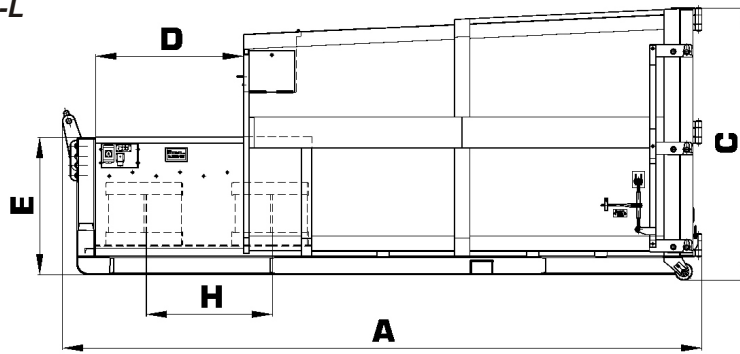

Type MPC-A

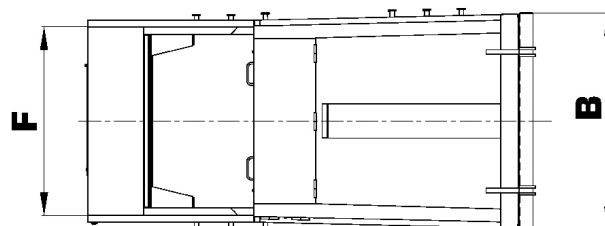
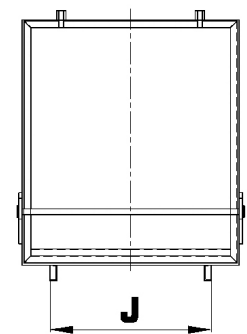
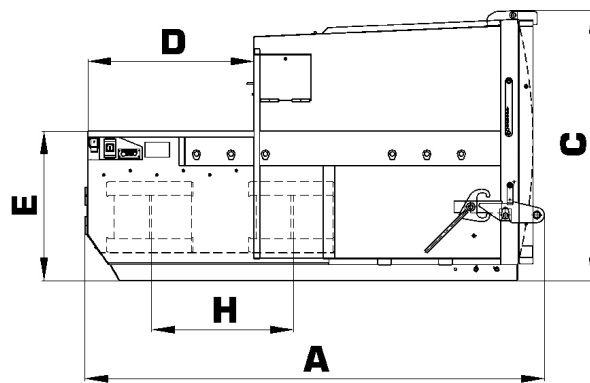

ANNEX: LUBRICATIONS SCHEME MPC-A

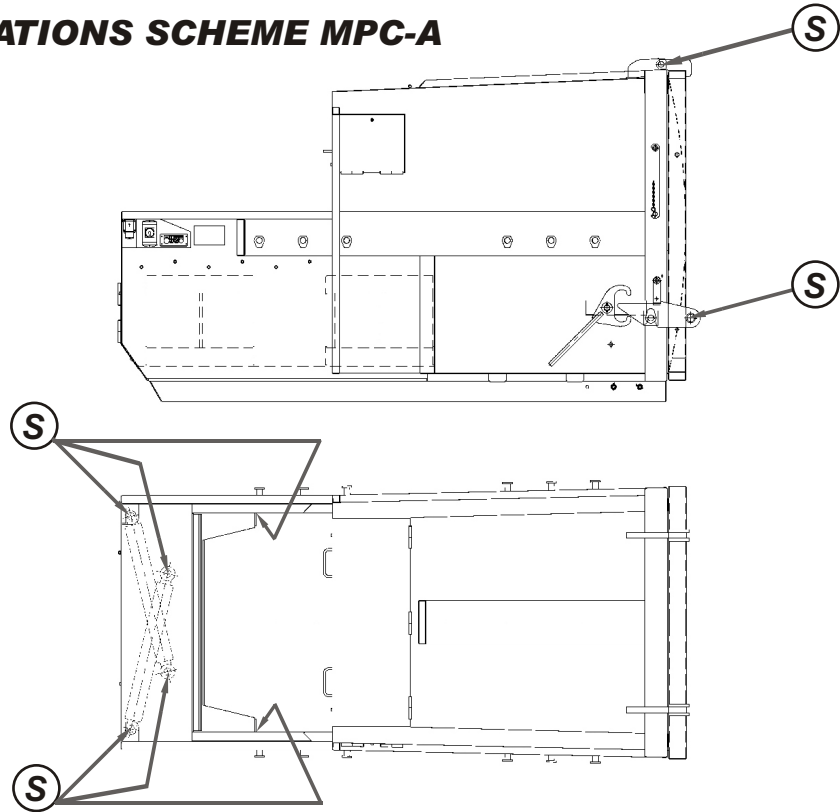

ANNEX: LUBRICATIONS SCHEME MPC-K and MPC-L

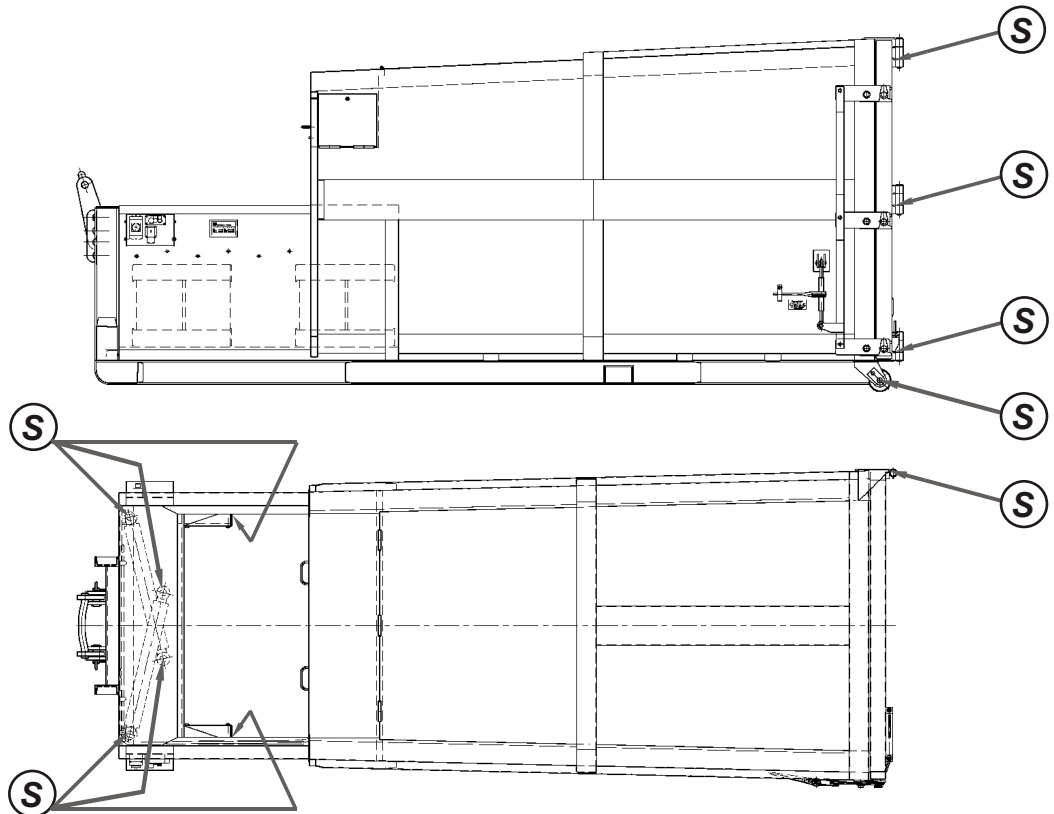

ANNEX: HYDRAULIC DIAGRAM MPC-A, MPC-K AND MPC-L

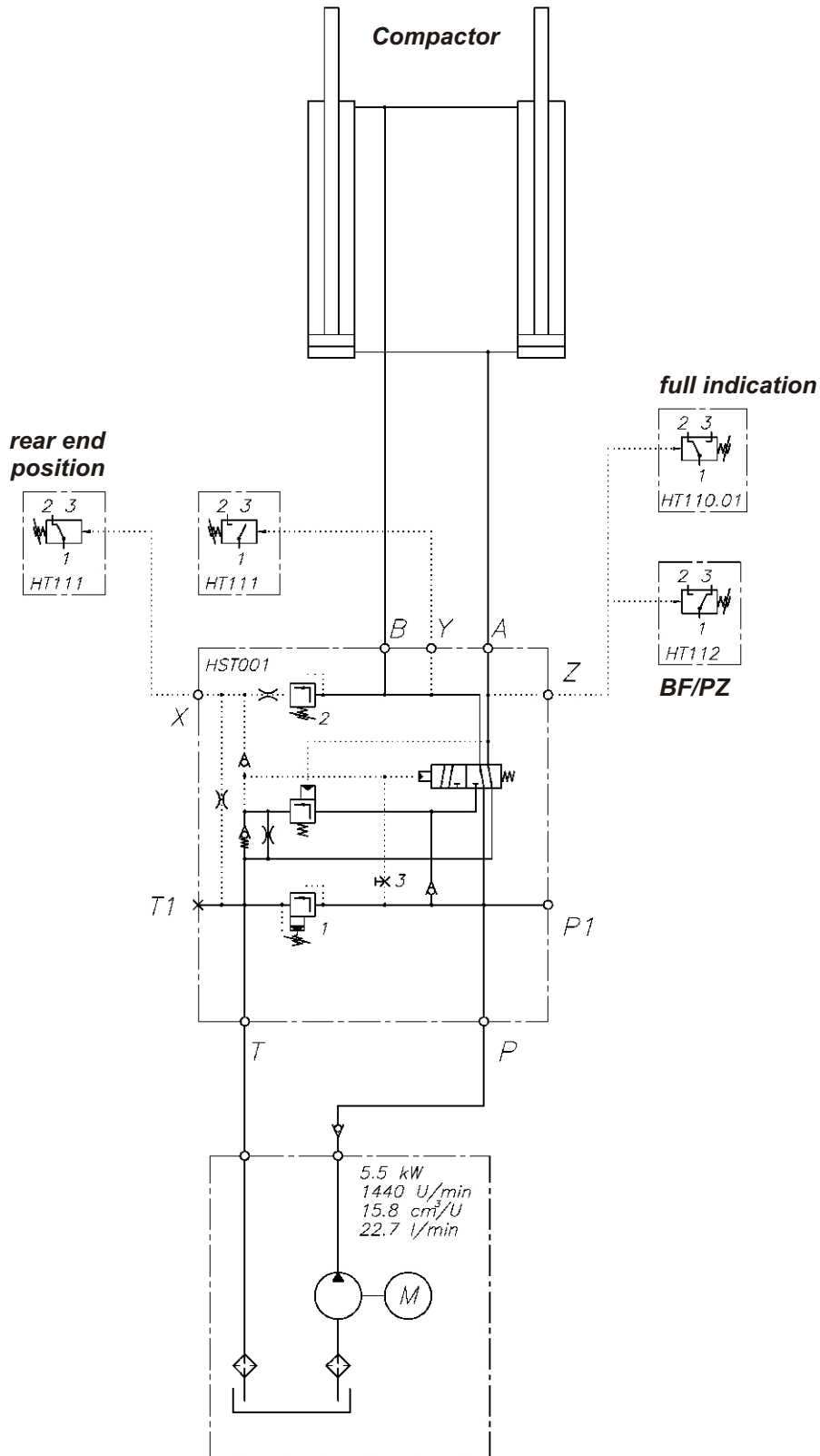

ANNEX: CIRCUIT DIAGRAM MPC-A; MPC-K AND MPC-L Standard design

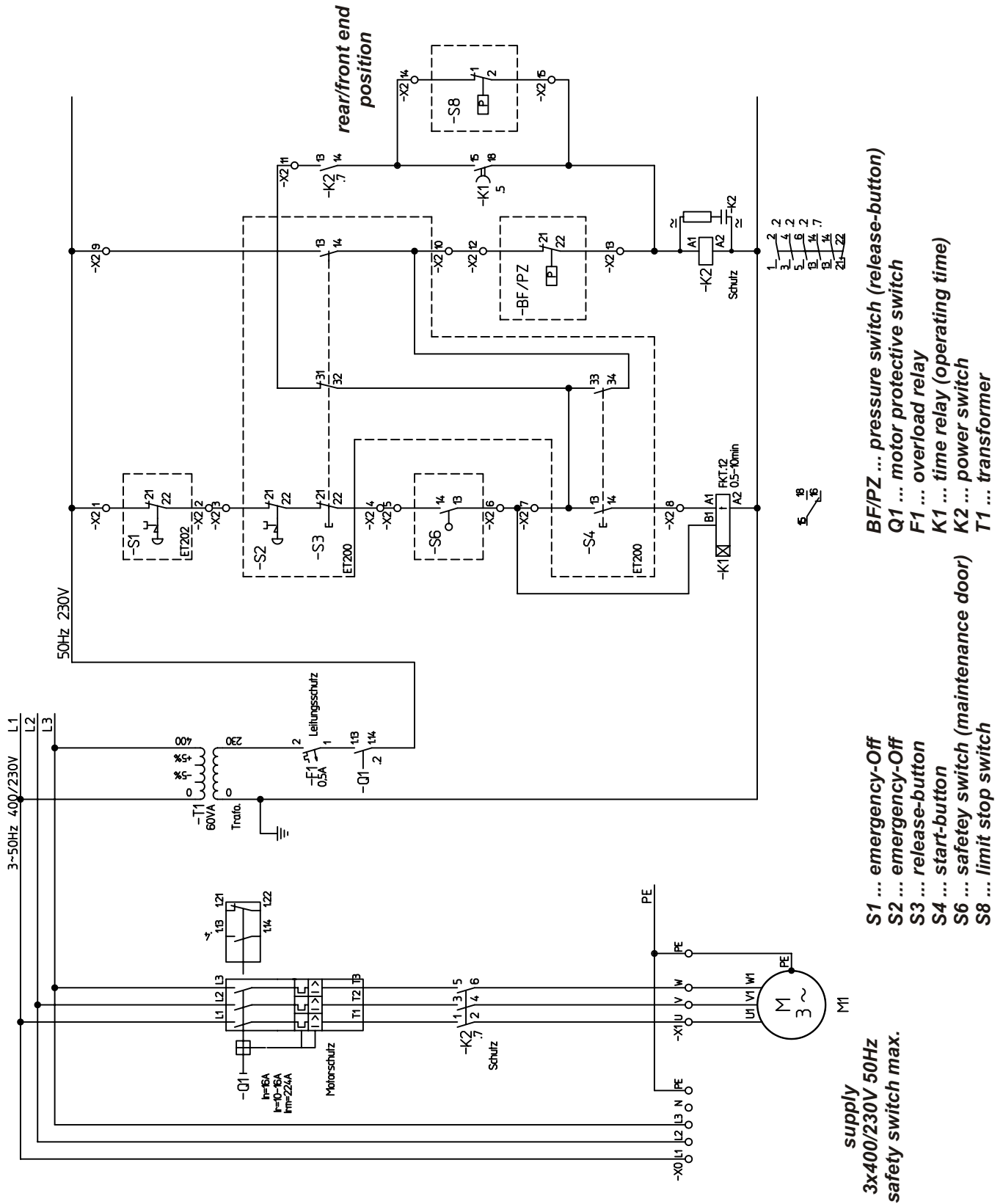

ANNEX: CIRCUIT DIAGRAM MPC-A; MPC-K AND MPC-L 3/4 full indication

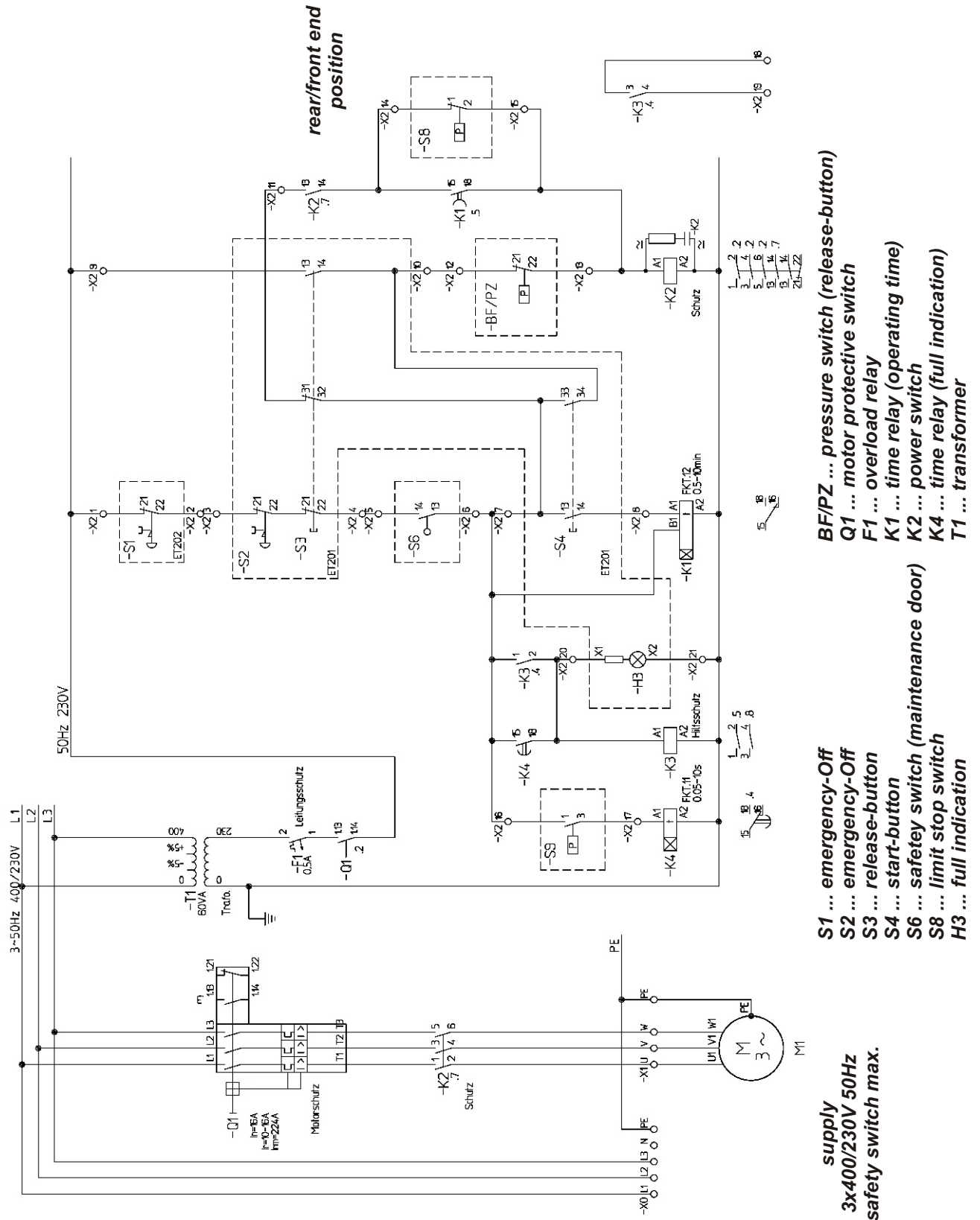

EC DECLARATION OF CONFORMITY as defined by machinery directive 98/37/EG

We herewith declare that the below referenced machine complies with the safety provisions of annex I of machinery directive 98/37/EEC.

This declaration loses effects in case of inadequate use or modification of the machine not authorised by the supplier.

Machine description: waste compactor MPC-A

Machine types **MPC8-A**
 MPC10-A
 MPC12-A
 MPC15-A

Applied harmonised standards in particular:

98/37/EG-MSV BGBl.Nr. 306/1994

EN292, EN294, EN349, EN418, EN811, EN953, EN954-1, EN60204-1

Applied national technical standards and specifications in particular:

EN 292-1
EN 292-2
EN 294
EN 349
EN 418
EN 811
EN 953
EN 954-1
EN 60204-1
GUV 17.3
DIN 30720

Location and date: Vienna, 27th.10.2003

.....
Geschäftsleitung

EC DECLARATION OF CONFORMITY as defined by machinery directive 98/37/EG

We herewith declare that the below referenced machine complies with the safety provisions of annex I of machinery directive 98/37/EEC.

This declaration loses effects in case of inadequate use or modification of the machine not authorised by the supplier.

Machine description: waste compactor MPC-K

Machine types **MPC16-K**
 MPC18-K
 MPC20-K
 MPC25-K

Applied harmonised standards in particular:

98/37/EG-MSV BGBl.Nr. 306/1994

EN292, EN294, EN349, EN418, EN811, EN953, EN954-1, EN60204-1

Applied national technical standards and specifications in particular:

EN 292-1
EN 292-2
EN 294
EN 349
EN 418
EN 811
EN 953
EN 954-1
EN 60204-1
GUV 17.3
DIN 30722

Location and date: Vienna, 27th.10.2003

.....
Geschäftsleitung

EC DECLARATION OF CONFORMITY as defined by machinery directive 98/37/EG

We herewith declare that the below referenced machine complies with the safety provisions of annex I of machinery directive 98/37/EEC.

This declaration loses effects in case of inadequate use or modification of the machine not authorised by the supplier.

Machine description: waste compactor MPC-L

Machine types **MPC16-L**
 MPC18-L
 MPC20-L
 MPC23-L

Applied harmonised standards in particular:

98/37/EG-MSV BGBl.Nr. 306/1994

EN292, EN294, EN349, EN418, EN811, EN953, EN954-1, EN60204-1

Applied national technical standards and specifications in particular:

EN 292-1
EN 292-2
EN 294
EN 349
EN 418
EN 811
EN 953
EN 954-1
EN 60204-1
GUV 17.3
DIN 30722

Location and date: Vienna, 27th. 10. 2003

.....
Geschäftsleitung



GUTACHTEN-CERTIFICATE

über die Konformitätsuntersuchung-*about conformity assessment*

TÜV-A-MHF/MG03-04753

Auftraggeber:
Applicant:

Werner & Weber
Warenhandels GmbH
Margaretengürtel 18 / 2
1050 Wien

Hersteller:
Manufacturer:

w. o.

Art der Maschine:
Product:

Mobile Müllpresse
mobile waste-press

Bauart / Type:
Design / Type:

MPC.. - (Typenumfang siehe Beiblatt)
MPC.. - . (Range of types see supplement)

untersuchte Maschine / Seriennr.:
Checked type / serial nr.:

MPC 25 – K / 0603457

Beschreibung:
Description:

Mobile elektrohydraulische Müllpresse für allgemeine Anwendung,
ausgeführt für Absetz- bzw. Abrollkipper
*Mobile elektro-hydraulic waste-press for common use; built for transport
by multi-bucket-system-vehicles.*

Prüfgrundlagen:
Test basis:

EG- Richtlinie Maschinen 98/37/EG (entspr. MSV, BGBL 306/1994 idgF.)
EC-directive Machinery 98/37/EC (i.e. MSV, BGBL 306/1994 idgF)
EN 292, EN 294, EN 349, EN 418, EN 811, EN 953, EN 954-1, EN 60204-1

Prüfungen:
Tests:

- Prüfung der technischen Unterlagen - *check of technical file*
- Prüfung der Risikoanalyse gemäß EN 1050 - *check of risk analysis according to EN 1050*
- praktische Funktions- und Belastungsprüfungen - *practical tests of function and loading*
- Prüfung der Betriebsanleitung - *check of instruction handbook*

Bemerkungen:
Remarks:

Zusatzeinrichtungen : Deckel mit automatischem Deckelöffner und zusätzlicher seitlicher
Einwurfüre
*supplementary equipment: Cover with automatic cover-opener and additional drop in door in
side*

MG03-04753

Ergebnis / Result:

Die Prüfungen/Untersuchungen der o. a. Maschine zeigen Übereinstimmung mit den grundlegenden Sicherheits- u. Gesundheitsanforderungen der genannten Richtlinie. Grundlage dieses Gutachtens ist das zur Zeit der Prüfung vorgelegte Prüfmuster und die technische Dokumentation. Für die Serienfertigung sind seitens des Herstellers geeignete Maßnahmen im Sinne der Richtlinie zu treffen.

The above mentioned product corresponds to the essential health and safety requirements of the above mentioned directive. The certificate is based on the test specimen and the technical documentation subjected to the test. For series manufacture the manufacturer has to take internal measures within the meaning of the directive.

Ausstellungsdatum / date of issue:

Wien, am 12. November 2003



Prüfstelle / examining department:

TÜV Österreich

Maschinen-, Hebe- und Fördertechnik

Maschinen- und Gerätesicherheit

Sachverständiger/expert:

Ing. S. König

Beiblatt zu TÜV-A-MHF/MG03-04753
 Supplement to TÜV-A-MHF/MG03-04753

Technische Daten :
 Technical specifications:

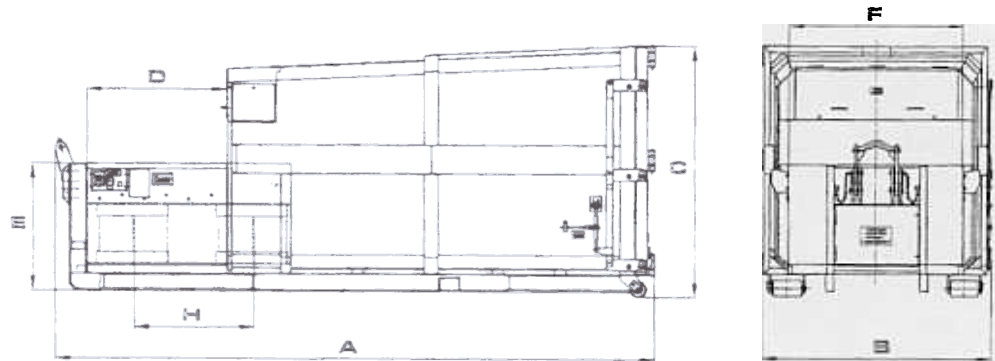

Aufnahmesystem		Absetzkipper				Abrollkipper				Abrollkipper			
Type		MPC8-A	MPC10-A	MPC12-A	MPC16-K	MPC18-K	MPC20-K	MPC25-K	MPC16-L	MPC18-L	MPC20-L	MPC23-L	
Containerinhalt netto	[m ³]	8	10	12	16	18	20	25	16	18	20	23	
Preßkammerinhalt	[m ³]	1,72	1,72	1,72	1,91	1,91	1,91	1,91	3,19	3,19	3,19	3,19	
Füllvolumen	[m ³]	1,22	1,22	1,22	1,36	1,36	1,36	1,36	2,2	2,2	2,2	2,2	
Min. theoretische Hubzeit vor-zurück	[sec]	23	23	23	30	30	30	30	50	50	50	50	
Max. theoretische Preßleistung	[m ³ /h]	190	190	190	164	164	164	164	162	162	162	162	
Preßkraft am Zylinder	[kN]	230	230	230	330	330	330	330	330	330	330	330	
Gesamtlänge	A [mm]	3970	4520	5170	5370	5770	6220	7220	6260	6660	7110	7660	
Außenbreite	B [mm]	1990	1990	1990	2420	2420	2420	2420	2420	2420	2420	2420	
Gesamthöhe	C [mm]	2360	2360	2360	2650	2650	2650	2650	2650	2650	2650	2650	
Einwurfhöhe	E [mm]	1300	1300	1300	1340	1340	1340	1340	1340	1340	1340	1340	
Einwurfbreite	F [mm]	1630	1630	1630	1820	1820	1820	1820	1820	1820	1820	1820	
Preßschlhub	H [mm]	1230	1230	1230	1230	1230	1230	1230	1980	1980	1980	1980	
Leergewicht	[kg]	3160	3310	3520	4030	4150	4290	4610	4520	4640	4770	5020	
Höchstzulässiges Gesamtgewicht	[kg]	12000	12000	12000	15000	15000	15000	15000	15000	15000	15000	15000	
Elektroanschluß		Motor 5,5 kW / 400V, 50Hz-Normstecker CEE-Form 16A, 5-polig											

Technische Änderungen vorbehalten